**Geometrical product specifications
(GPS) — Dimensional and geometrical
tolerances for moulded parts —**

**Part 3:
General dimensional and geometrical
tolerances and machining allowances for
castings**

*Spécification géométrique des produits (GPS) — Tolérances
dimensionnelles et géométriques des pièces moulées —*

*Partie 3: Tolérances dimensionnelles et géométriques générales et
surépaisseurs d'usinage pour les pièces moulées*



Reference number
ISO 8062-3:2007(E)

© ISO 2007

PDF disclaimer

This PDF file may contain embedded typefaces. In accordance with Adobe's licensing policy, this file may be printed or viewed but shall not be edited unless the typefaces which are embedded are licensed to and installed on the computer performing the editing. In downloading this file, parties accept therein the responsibility of not infringing Adobe's licensing policy. The ISO Central Secretariat accepts no liability in this area.

Adobe is a trademark of Adobe Systems Incorporated.

Details of the software products used to create this PDF file can be found in the General Info relative to the file; the PDF-creation parameters were optimized for printing. Every care has been taken to ensure that the file is suitable for use by ISO member bodies. In the unlikely event that a problem relating to it is found, please inform the Central Secretariat at the address given below.



COPYRIGHT PROTECTED DOCUMENT

© ISO 2007

All rights reserved. Unless otherwise specified, no part of this publication may be reproduced or utilized in any form or by any means, electronic or mechanical, including photocopying and microfilm, without permission in writing from either ISO at the address below or ISO's member body in the country of the requester.

ISO copyright office
Case postale 56 • CH-1211 Geneva 20
Tel. + 41 22 749 01 11
Fax + 41 22 749 09 47
E-mail copyright@iso.org
Web www.iso.org

Published in Switzerland

Contents

Page

Foreword.....	iv
Introduction	v
1 Scope	1
2 Normative references	1
3 Terms and definitions.....	2
4 Abbreviated terms	2
5 Tolerance grades	3
5.1 General.....	3
5.2 Dimensional casting tolerance grades (DCTG)	3
5.3 Geometrical casting tolerance grades (GCTG).....	4
6 Surface mismatch (SMI)	7
7 Wall thickness	7
8 Required machining allowances (RMA)	7
8.1 General.....	7
8.2 Required machining allowance grades (RMAG).....	8
9 Indication on drawings.....	8
9.1 Indication of general dimensional casting tolerances.....	8
9.2 Indication of required machining allowances.....	9
9.3 Indication of geometrical casting tolerances	9
10 Rejection.....	10
Annex A (informative) Casting tolerances and geometrical tolerances	11
Annex B (informative) Required machining allowance grades (RMAG).....	14
Annex C (informative) Concept of general tolerancing of characteristics	15
Annex D (informative) Datums for general geometrical tolerances.....	17
Annex E (informative) Application of general geometrical tolerances for castings	21
Annex F (informative) Relation to the GPS matrix model	29
Bibliography	30

Foreword

ISO (the International Organization for Standardization) is a worldwide federation of national standards bodies (ISO member bodies). The work of preparing International Standards is normally carried out through ISO technical committees. Each member body interested in a subject for which a technical committee has been established has the right to be represented on that committee. International organizations, governmental and non-governmental, in liaison with ISO, also take part in the work. ISO collaborates closely with the International Electrotechnical Commission (IEC) on all matters of electrotechnical standardization.

International Standards are drafted in accordance with the rules given in the ISO/IEC Directives, Part 2.

The main task of technical committees is to prepare International Standards. Draft International Standards adopted by the technical committees are circulated to the member bodies for voting. Publication as an International Standard requires approval by at least 75 % of the member bodies casting a vote.

Attention is drawn to the possibility that some of the elements of this document may be the subject of patent rights. ISO shall not be held responsible for identifying any or all such patent rights.

ISO 8062-3 was prepared by Technical Committee ISO/TC 213, *Dimensional and geometrical product specifications and verification*.

This first edition of ISO 8062-3, together with ISO 8062-1 and ISO/TS 8062-2, cancels and replaces ISO 8062:1994, of which it constitutes a technical revision.

ISO 8062 consists of the following parts, under the general title *Geometrical product specifications (GPS) — Dimensional and geometrical tolerances for moulded parts*:

- *Part 1: Vocabulary*
- *Part 3: General dimensional and geometrical tolerances and machining allowances for castings*

Rules is to form the subject of a future Part 2 [Technical Specification].

Introduction

This part of ISO 8062 is a geometrical product specification (GPS) standard and is to be regarded as a complementary process-specific tolerance standard (see ISO/TR 14638). It influences chain link 2 of the chain of standards on mouldings.

For more detailed information about the relation of this part of ISO 8062 to other standards and the GPS matrix model, see Annex F.

This part of ISO 8062 defines a system of tolerance grades and machining allowance grades for cast metals and their alloys.

The specified system applies if the manufacturer provides a pattern or die equipment, or accepts responsibility for proving it.

The tolerances specified for a casting may determine the casting method. It is therefore recommended, before the design or the order is finalized, that the customer liaise with the foundry to discuss:

- a) the proposed casting design and accuracy required;
- b) machining requirements;
- c) the method of casting;
- d) the location of the parting surfaces and the necessary draft angles;
- e) the number of castings to be manufactured;
- f) the casting equipment involved;
- g) the consequences of the wear-out of the equipment during its life cycle;
- h) the datum system in accordance with ISO 5459;
- i) the casting alloy;
- j) any special requirements, e.g. individual dimensional and geometrical tolerances, fillet radii, tolerances and individual machining allowances;

NOTE Because the dimensional and geometrical accuracy of a casting is related to production factors, tolerance grades which can be achieved for various methods and metals are described in Annex A.

- k) dimensional tolerances for long series and mass production, where development, adjustment and maintenance of casting equipment make it possible to achieve close tolerances;
- l) dimensional tolerances for short series and single production;
- m) geometrical tolerances.

Information on typical required machining allowance grades is given in Annex B.

Geometrical product specifications (GPS) — Dimensional and geometrical tolerances for moulded parts —

Part 3: General dimensional and geometrical tolerances and machining allowances for castings

1 Scope

This part of ISO 8062 specifies general dimensional and geometrical tolerances, as well as machining allowance grades, for castings as delivered to the purchaser in accordance with ISO 8062-2. It is applicable for the tolerancing of dimensions and geometry, and required machining allowance of castings in all cast metals and their alloys produced by various casting manufacturing processes.

This part of ISO 8062 applies to both general dimensional and general geometrical tolerances (referred to in or near the title block of the drawing), unless otherwise specified, and where specifically referred to on the drawing by one of the references in Clause 9.

The dimensional tolerances covered by this part of ISO 8062 are tolerances for linear dimensions.

The geometrical tolerances covered by this part of ISO 8062 are:

- tolerances for straightness,
- flatness,
- roundness,
- parallelism,
- perpendicularity,
- symmetry, and
- coaxiality.

This part of ISO 8062 can be used for the selection of tolerance values for individual indications.

NOTE This part of ISO 8062 does not apply to 3D CAD models used without indicated dimensions.

2 Normative references

The following referenced documents are indispensable for the application of this document. For dated references, only the edition cited applies. For undated references, the latest edition of the referenced document (including any amendments) applies.

ISO 286-1:1988, *ISO system of limits and fits — Part 1: Bases of tolerances, deviations and fits*

ISO 1101:2004, *Geometrical Product Specifications (GPS) — Geometrical tolerancing — Tolerances of form, orientation, location and run-out*

ISO 8062-3:2007(E)

ISO 1302:2002, *Geometrical Product Specifications (GPS) — Indication of surface texture in technical product documentation*

ISO 5459:—¹⁾, *Geometrical product specifications (GPS) — Geometrical tolerancing — Datums and datum-systems*

ISO 8062-1:2007, *Geometrical product specifications (GPS) — Dimensional and geometrical tolerances for moulded parts — Part 1: Vocabulary*

ISO/TS 8062-2:—²⁾, *Geometrical product specifications (GPS) — Dimensional and geometrical tolerances for moulded parts — Part 2: Rules*

ISO 10135:—³⁾, *Geometrical product specifications (GPS) — Drawing indications for moulded parts in technical product documentation (TPD)*

ISO 10579:1993, *Technical drawings — Dimensioning and tolerancing — Non-rigid parts*

ISO 14405:—⁴⁾, *Geometrical product specifications (GPS) — Dimensional tolerancing — Linear sizes*

3 Terms and definitions

For the purposes of this document, the terms and definitions given in ISO 8062-1, ISO 1101 and ISO 5459 apply.

4 Abbreviated terms

Abbreviated terms are given in Table 1.

Table 1 — Abbreviated terms

Abbreviated term	Interpretation	Reference
DCT	Dimensional casting tolerance	5.2
DCTG	Dimensional casting tolerance grade	5.2
GCT	Geometrical casting tolerance	5.3
GCTG	Geometrical casting tolerance grade	5.3
RMA	Required machining allowance	Clause 8
RMAG	Required machining allowance grade	Clause 8
TP	Taper +	ISO 10135
TM	Taper -	ISO 10135
SMI	Surface mismatch	ISO 10135

1) To be published. Revision of ISO 5459:1981.

2) To be published. Revision of ISO 8062:1994.

3) To be published. Revision of ISO 10135:1994.

4) To be published.

5 Tolerance grades

5.1 General

Individual dimensional and geometrical tolerances shall be indicated in accordance with the relevant GPS standards on dimensional and geometrical tolerancing.

If using general tolerances, the necessity of smaller tolerances (for functional reasons) or of larger tolerances (for economical reasons) needs to be ascertained (see Annex C). In both cases, individual tolerances shall be indicated.

For drawings where the tolerances in accordance with this part of ISO 8062 only apply under specified, restricted conditions, ISO 10579 shall be referred to on the drawing.

5.2 Dimensional casting tolerance grades (DCTG)

Sixteen linear dimensional casting tolerance grades are defined and designated as DCTG 1 to DCTG 16 (see Table 2).

NOTE 1 For wall thicknesses, see Clause 7.

Table 2 — Linear dimensional casting tolerances (DCT)

Dimensions in millimetres

Nominal dimensions related to the moulded part		Linear dimensional tolerance for dimensional casting tolerance grade (DCTG) ^a															
		DCTG 1	DCTG 2	DCTG 3	DCTG 4	DCTG 5	DCTG 6	DCTG 7	DCTG 8	DCTG 9	DCTG 10	DCTG 11	DCTG 12	DCTG 13	DCTG 14	DCTG 15	DCTG 16 ^b
—	≤ 10	0,09	0,13	0,18	0,26	0,36	0,52	0,74	1	1,5	2	2,8	4,2	—	—	—	—
> 10	≤ 16	0,1	0,14	0,2	0,28	0,38	0,54	0,78	1,1	1,6	2,2	3	4,4	—	—	—	—
> 16	≤ 25	0,11	0,15	0,22	0,3	0,42	0,58	0,82	1,2	1,7	2,4	3,2	4,6	6	8	10	12
> 25	≤ 40	0,12	0,17	0,24	0,32	0,46	0,64	0,9	1,3	1,8	2,6	3,6	5	7	9	11	14
> 40	≤ 63	0,13	0,18	0,26	0,36	0,5	0,7	1	1,4	2	2,8	4	5,6	8	10	12	16
> 63	≤ 100	0,14	0,2	0,28	0,4	0,56	0,78	1,1	1,6	2,2	3,2	4,4	6	9	11	14	18
> 100	≤ 160	0,15	0,22	0,3	0,44	0,62	0,88	1,2	1,8	2,5	3,6	5	7	10	12	16	20
> 160	≤ 250	—	0,24	0,34	0,5	0,7	1	1,4	2	2,8	4	5,6	8	11	14	18	22
> 250	≤ 400	—	—	0,4	0,56	0,78	1,1	1,6	2,2	3,2	4,4	6,2	9	12	16	20	25
> 400	≤ 630	—	—	—	0,64	0,9	1,2	1,8	2,6	3,6	5	7	10	14	18	22	28
> 630	≤ 1 000	—	—	—	—	1	1,4	2	2,8	4	6	8	11	16	20	25	32
> 1 000	≤ 1 600	—	—	—	—	—	1,6	2,2	3,2	4,6	7	9	13	18	23	29	37
> 1 600	≤ 2 500	—	—	—	—	—	—	2,6	3,8	5,4	8	10	15	21	26	33	42
> 2 500	≤ 4 000	—	—	—	—	—	—	—	4,4	6,2	9	12	17	24	30	38	49
> 4 000	≤ 6 300	—	—	—	—	—	—	—	—	7	10	14	20	28	35	44	56
> 6 300	≤ 10 000	—	—	—	—	—	—	—	—	—	11	16	23	32	40	50	64

^a For wall thicknesses in grades DCTG 1 to DCTG 15, one grade coarser applies (see Clause 7).

^b Grade DCTG 16 exists only for wall thicknesses of castings generally specified to DCTG 15.

NOTE 2 Annex A gives recommendations for the application of the above tolerance grades.

As the default conditions for the dimensions, the casting tolerance shall be symmetrically disposed with respect to the nominal dimension, i.e. with one half on the positive side and one half on the negative side.

If agreed between manufacturer and purchaser for specific reasons, the casting tolerance may be asymmetric. In such cases, the casting tolerance shall be stated individually, in accordance with ISO 286-1 and ISO 14405, following the nominal dimensions of the final moulded part.

NOTE 3 In pressure die casting, an asymmetric tolerance disposition is often applied because of special technical reasons.

5.3 Geometrical casting tolerance grades (GCTG)

5.3.1 General

Seven geometrical casting tolerance grades (GCTG) are defined and designated as GCTG 2 to GCTG 8 (see Tables 3 to 6).

NOTE 1 GCT values are not given for grade GCTG 1. This grade is reserved for finer values which could be required in the future.

NOTE 2 See Annex E for application of general geometrical tolerances for castings.

General tolerances on form (straightness, flatness, roundness) and on orientation (angularity, parallelism, perpendicularity) do not apply to features with draft. These features need individual indicated tolerances, according to the function and to the manufacturer's advice.

Other geometrical tolerances than those given in Tables 3 to 6 (e.g. angularity, profile, position, common zone flatness) shall be indicated individually.

It is therefore recommended to acquire from the manufacturer the information about the design of the mould regarding the location of the parting surfaces and the amount of draft applied to the features, in order to complete the drawing (see Introduction).

5.3.2 Nominal dimensions

The nominal dimension to be used in Tables 3 to 6 shall be the longest nominal dimension of the moulded part of the considered feature, disregarding the nominal dimension of fillets and chamfers that are not individually indicated.

5.3.3 Datums

5.3.3.1 Datums for general orientation tolerances

For general orientation tolerances in accordance with ISO 8062-3, a datum system shall be specified on the drawing and identified by the indication "ISO 8062-3 DS" in or near the title block of the drawing, as shown in Figure 1.

ISO 8062-3 DS

A	B	C
---	---	---

Figure 1 — Drawing indication for the datum system for general orientation tolerances in accordance with ISO 8062-3

NOTE This datum system does not apply to general geometrical tolerances on coaxiality and symmetry (see 5.3.3.2 and 5.3.3.3).

5.3.3.2 Datums for general coaxiality tolerances

For datums of general coaxiality tolerances, the following conditions apply.

- If one cylindrical feature (internal or external) extends over the whole length of all other cylindrical coaxial features, the axis of this feature applies as the (single) datum (see Figure D.1).
- Otherwise, a common datum applies, composed of the axes of the two most separated features on the drawing centre line considered (see Figure D.2). If more than one possibility exist (e.g. internal or external features), the feature with the largest diameter applies (see Figure D.3).

The general tolerances for coaxiality also apply to the datum features themselves, if a common datum applies.

5.3.3.3 Datums for general symmetry tolerances

For datums of general symmetry tolerances, the following conditions apply.

- If one feature of size (internal or external), composed of two parallel opposite planes, extends over the whole length of all other co-symmetrical features, the median plane of this feature applies as the (single) datum (see Figure D.4).
- Otherwise, a common datum applies, composed of the median planes and/or median lines of the two most separated feature on the drawing centre line (plane) considered (see Figure D.5). If more than one possibility exist, the feature(s) with the largest size(s) apply (see Figure D.6). One of the two datum features may be cylindrical (see Figure D.7).

The general tolerances for symmetry also apply to the datum features themselves, if a common datum applies.

Table 3 — Casting tolerances for straightness

Dimensions in millimetres

Nominal dimension related to the moulded part		Straightness tolerance for geometrical casting tolerance grade (GCTG)						
		GCTG 2	GCTG 3	GCTG 4	GCTG 5	GCTG 6	GCTG 7	GCTG 8
—	≤ 10	0,08	0,12	0,18	0,27	0,4	0,6	0,9
> 10	≤ 30	0,12	0,18	0,27	0,4	0,6	0,9	1,4
> 30	≤ 100	0,18	0,27	0,4	0,6	0,9	1,4	2
> 100	≤ 300	0,27	0,4	0,6	0,9	1,4	2	3
> 300	≤ 1 000	0,4	0,6	0,9	1,4	2	3	4,5
> 1 000	≤ 3 000	—	—	—	3	4	6	9
> 3 000	≤ 6 000	—	—	—	6	8	12	18
> 6 000	≤ 10 000	—	—	—	12	16	24	36

Table 4 — Casting tolerances for flatness

Dimensions in millimetres

Nominal dimension related to the moulded part		Flatness tolerance for geometrical casting tolerance grade (GCTG)						
		GCTG 2	GCTG 3	GCTG 4	GCTG 5	GCTG 6	GCTG 7	GCTG 8
—	≤ 10	0,12	0,18	0,27	0,4	0,6	0,9	1,4
> 10	≤ 30	0,18	0,27	0,4	0,6	0,9	1,4	2
> 30	≤ 100	0,27	0,4	0,6	0,9	1,4	2	3
> 100	≤ 300	0,4	0,6	0,9	1,4	2	3	4,5
> 300	≤ 1 000	0,6	0,9	1,4	2	3	4,5	7
> 1 000	≤ 3 000	—	—	—	4	6	9	14
> 3 000	≤ 6 000	—	—	—	8	12	18	28
> 6 000	≤ 10 000	—	—	—	16	24	36	56

Table 5 — Casting tolerances for roundness, parallelism, perpendicularity and symmetry

Dimensions in millimetres

Nominal dimension related to the moulded part		Tolerance for geometrical casting tolerance grade (GCTG)						
		GCTG 2	GCTG 3	GCTG 4	GCTG 5	GCTG 6	GCTG 7	GCTG 8
—	≤ 10	0,18	0,27	0,4	0,6	0,9	1,4	2
> 10	≤ 30	0,27	0,4	0,6	0,9	1,4	2	3
> 30	≤ 100	0,4	0,6	0,9	1,4	2	3	4,5
> 100	≤ 300	0,6	0,9	1,4	2	3	4,5	7
> 300	≤ 1 000	0,9	1,4	2	3	4,5	7	10
> 1 000	≤ 3 000	—	—	—	6	9	14	20
> 3 000	≤ 6 000	—	—	—	12	18	28	40
> 6 000	≤ 10 000	—	—	—	24	36	56	80

Table 6 — Casting tolerances for coaxiality

Dimensions in millimetres

Nominal dimension related to the moulded part		Coaxiality tolerance for geometrical casting tolerance grade (GCTG)						
		GCTG 2	GCTG 3	GCTG 4	GCTG 5	GCTG 6	GCTG 7	GCTG 8
—	≤ 10	0,27	0,4	0,6	0,9	1,4	2	3
> 10	≤ 30	0,4	0,6	0,9	1,4	2	3	4,5
> 30	≤ 100	0,6	0,9	1,4	2	3	4,5	7
> 100	≤ 300	0,9	1,4	2	3	4,5	7	10
> 300	≤ 1 000	1,4	2	3	4,5	7	10	15
> 1 000	≤ 3 000	—	—	—	9	14	20	30
> 3 000	≤ 6 000	—	—	—	18	28	40	60
> 6 000	≤ 10 000	—	—	—	36	56	80	120

Other geometrical tolerances shall be indicated by individually indicated geometrical tolerances.

6 Surface mismatch (SMI)

As the default condition, the surface mismatch *A* is controlled indirectly by verification of the linear dimensions in accordance with Table 2 (see Figure 2). The surface mismatch may therefore vary between zero and the value given in Table 2, depending on the actual local sizes of the feature.

On features without draft, surface mismatch is also controlled and therefore included in the form tolerances for straightness, flatness and roundness given in Tables 3 to 5.

NOTE This is an overruling of the principle of independency, because it is often not known whether a parting line exists and, if so, whether the particular feature is affected.

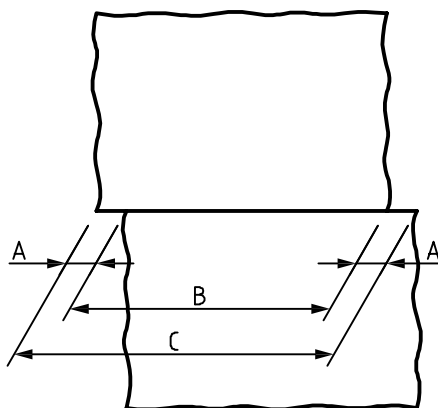

Key

- A surface mismatch
- B minimum dimension
- C maximum dimension

Figure 2 — Limitation of surface mismatch by linear dimension

If it is necessary to restrict further the value of the surface mismatch, the maximum permissible surface mismatch shall be stated individually in accordance with ISO 10135.

7 Wall thickness

As the default condition, the tolerance for wall thickness in grades DCTG 1 to DCTG 15 shall be one grade coarser than the general tolerance for other dimensions, e.g. if there is a general tolerance on a drawing of DCTG 10, the tolerance on wall thicknesses shall be DCTG 11.

8 Required machining allowances (RMA)

8.1 General

As a general condition, the specified required machining allowance grades, RMAG, in accordance with this part of ISO 8062 apply for the entire final moulded part (see Clause 9), i.e. only one value is specified for all surfaces to be machined, and this value shall be selected from the appropriate dimension range according to the largest overall dimension (see Table 7).

NOTE In sand casting, top surfaces may need more machining allowance than other surfaces. For these surfaces, coarser RMA grades can be selected. Individual machining allowances shall be indicated in accordance with ISO 1302.

8.2 Required machining allowance grades (RMAG)

Ten grades of required machining allowance grades are defined and designated RMAG A to RMAG K (see Table 7).

NOTE Grades recommended for particular alloys and manufacturing methods are shown in Table B.1 for information only.

Table 7 — Required machining allowance

Dimensions in millimetres

Largest overall dimension		Machining allowance for required machining allowance grade (RMAG)									
		RMAG A	RMAG B	RMAG C	RMAG D	RMAG E	RMAG F	RMAG G	RMAG H	RMAG J	RMAG K
—	≤ 40	0,1	0,1	0,2	0,3	0,4	0,5	0,5	0,7	1	2
> 40	≤ 63	0,1	0,2	0,3	0,3	0,4	0,5	0,7	1	1,4	3
> 63	≤ 100	0,2	0,3	0,4	0,5	0,7	1	1,4	2	2,8	4
> 100	≤ 160	0,3	0,4	0,5	0,8	1,1	1,5	2,2	3	4	6
> 160	≤ 250	0,3	0,5	0,7	1	1,4	2	2,8	4	5,5	8
> 250	≤ 400	0,4	0,7	0,9	1,3	1,8	2,5	3,5	5	7	10
> 400	≤ 630	0,5	0,8	1,1	1,5	2,2	3	4	6	9	12
> 630	≤ 1 000	0,6	0,9	1,2	1,8	2,5	3,5	5	7	10	14
> 1 000	≤ 1 600	0,7	1	1,4	2	2,8	4	5,5	8	11	16
> 1 600	≤ 2 500	0,8	1,1	1,6	2,2	3,2	4,5	6	9	13	18
> 2 500	≤ 4 000	0,9	1,3	1,8	2,5	3,5	5	7	10	14	20
> 4 000	≤ 6 300	1	1,4	2	2,8	4	5,5	8	11	16	22
> 6 300	≤ 10 000	1,1	1,5	2,2	3	4,5	6	9	12	17	24

NOTE Grades A and B are only applied in special cases, e.g. with series production in which the pattern equipment, the casting procedure and the machining procedure with regard to clamping surfaces and datum surfaces or targets have been agreed between the customer and the foundry.

9 Indication on drawings

9.1 Indication of general dimensional casting tolerances

General casting tolerances in accordance with this part of ISO 8062 shall be indicated on the drawing in or near the title block, in the following ways:

a) with general information relating to tolerances:

- “General tolerances”;
- “ISO 8062-3”;
- the tolerance grade (DCTG) in accordance with Table 2;

EXAMPLE **General tolerances ISO 8062-3 — DCTG 12.**

b) if further restriction of the surface mismatch is required (see Clause 6):

- “General tolerances”;

- “ISO 8062-3”;
- the tolerance grade (DCTG) in accordance with Table 2;
- “maximum surface mismatch” and its required limit value in accordance with ISO 10135.

EXAMPLE **General tolerances ISO 8062-3 — DCTG 12 — SMI $\pm 1,5$.**

NOTE For more information, see Annexes A and C.

9.2 Indication of required machining allowances

Required machining allowances shall be indicated on the drawing in or near the title block in the following ways:

a) with general information relating to tolerances and required machining allowances:

- “General tolerances”;
- “ISO 8062-3”;
- the casting tolerance grade (DCTG) in accordance with Table 2;
- the required machining allowance (RMA) in accordance with Table 7 and the corresponding grade in brackets.

EXAMPLE For a required machining allowance of 6 mm in grade H for a casting in the largest dimension range over 400 mm and up to 630 mm (with general tolerance for the casting ISO 8062-3 — DCTG 12):

General tolerances ISO 8062-3 — DCTG 12 — RMA 6 (RMAG H).

and/or

b) where a local machining allowance is required on a surface of the moulded part, it shall be specified individually in accordance with ISO 1302, as shown in Figure 3.

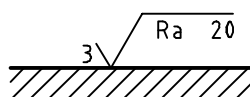

Figure 3 — Indication of required machining allowance on individual surfaces

NOTE For more information, see Annex B.

9.3 Indication of geometrical casting tolerances

General geometrical casting tolerances in accordance with this part of ISO 8062 shall be stated on the drawing in one of the following ways.

a) If general tolerances in accordance with this part of ISO 8062 apply, in conjunction with the general casting tolerances in accordance with Table 2, the following information shall be indicated in or near the title block:

- “General tolerances”;

- “ISO 8062-3”;
- the casting tolerance grade (DCTG) in accordance with Table 2;
- the required machining allowance (RMA) in accordance with Table 7, and the corresponding grade in brackets;
- the geometrical casting tolerance grade (GCTG) in accordance with Tables 3 to 6.

EXAMPLE General tolerances ISO 8062-3 — DCTG 12 — RMA 6 (RMAG H) — GCTG 7.

b) For general geometrical casting tolerances in accordance with Tables 3 to 6:

- “General tolerances”;
- “ISO 8062-3”;
- the geometrical casting tolerance grade (GCTG) in accordance with Tables 3 to 6.

EXAMPLE General tolerances ISO 8062-3 — GCTG 7.

For the concept of general tolerancing, see Annex C. For the selection of general tolerance grades, see Introduction and Annex A. For the selection of required machining allowance grades, see Annex B.

10 Rejection

Unless otherwise stated, workpieces exceeding the general tolerances shall not lead to automatic rejection, provided that the ability of the workpiece to function is not impaired (see C.4).

Annex A (informative)

Casting tolerances and geometrical tolerances

A.1 Tables A.1 and A.2 show dimensional tolerances and Table A.3 shows geometrical tolerance grades which can normally be expected in casting processes. As indicated in the Introduction to this part of ISO 8062, the accuracy of a casting process is dependent upon many factors, including:

- a) the complexity of the design;
- b) the type of pattern equipment or die equipment;
- c) the metal or alloy concerned;
- d) the condition of patterns or dies;
- e) the foundry working methods.

A.2 For long series of repetitive work, it may be possible to make adjustments and to control core positions carefully to achieve dimensional tolerance grades finer than those indicated in Table A.1.

A.3 In sand casting for short production series and for single castings, it is generally impractical and uneconomical to use metal patterns and to develop equipment and casting procedures resulting in narrow tolerances. The wider tolerances for this class of manufacture are shown in Table A.2.

A.4 The dimensional tolerances in Table 2 are based on foundry experience data. These data were used to construct a series of smooth curves using ratios of

$\sqrt{2}$ for grades DCTG 1 to DCTG 13, and

$\sqrt[3]{2}$ for grades DCTG 13 to DCTG 16.

Many dimensions of a casting are affected by the presence of a mould joint or a core, requiring increased dimensional tolerance. Since the designer will not necessarily be aware of the mould and core layout to be used, increases have already been included in Table 2.

A.5 The geometrical tolerances in Tables 3 to 6 are based on foundry experience data.

Table A.1 — Dimensional casting tolerance grades for long-series or mass production raw castings

Method	Dimensional casting tolerance grade (DCTG) for casting material								
	Steel	Grey iron	S.G. iron	Malleable iron	Copper alloys	Zinc alloys	Light metal alloys	Nickel-based alloys	Cobalt-based alloys
Sand cast, hand moulding	11 to 14	11 to 14	11 to 14	11 to 14	10 to 13	10 to 13	9 to 12	11 to 14	11 to 14
Sand cast, machine moulding and shell moulding	8 to 12	8 to 12	8 to 12	8 to 12	8 to 10	8 to 10	7 to 9	8 to 12	8 to 12
Metallic permanent mould (except pressure die casting)	—	7 to 9	7 to 9	7 to 9	7 to 9	7 to 9	6 to 8	—	—
Pressure die casting	—	—	—	—	6 to 8	3 to 6	b	—	—
Investment casting	a	a	a	—	a	—	a	a	a

NOTE 1 The tolerance grades indicated are those which can normally be held for castings produced in long series and if production factors influencing the dimensional accuracy of the casting have been fully developed.

NOTE 2 For complex castings, one grade coarser is recommended.

a For investment castings, the following apply depending on the largest overall dimension:
 — ≤ 100 mm: grade 4 to 6
 — > 100 mm ≤ 400 mm: grade 4 to 8
 — > 400 mm: grade 4 to 9.

b The largest overall dimension strongly influences the choice of the tolerance class. The following casting tolerance grades are recommended for the largest overall dimension, dimensional tolerance grade DCTG:
 — ≤ 50 mm: DCTG 6
 — > 50 mm ≤ 180 mm: DCTG 7
 — > 180 mm ≤ 500 mm: DCTG 8
 — > 500 mm: DCTG 9.

Table A.2 — Dimensional casting tolerance grades for short-series or single-production raw castings

Method	Moulding material	Dimensional casting tolerance grade (DCTG) for casting material							
		Steel	Grey iron	S.G. iron	Malleable iron	Copper alloys	Light metal alloys	Nickel-based alloys	Cobalt-based alloys
Sand cast, hand moulded	Clay-bonded	13 to 15	13 to 15	13 to 15	13 to 15	13 to 15	11 to 13	13 to 15	13 to 15
	Chemically bonded	12 to 14	11 to 14	11 to 14	11 to 14	10 to 13	10 to 13	12 to 14	12 to 14

NOTE The values in this table apply generally to nominal dimensions greater than 25 mm. For smaller dimensions, finer tolerances can normally be economically and practically held as follows:
 — nominal dimension up to 10 mm: three grades finer;
 — nominal dimensions 10 mm to 16 mm: two grades finer;
 — nominal dimensions 16 mm to 25 mm: one grade finer.

Table A.3 — Geometrical casting tolerance grades

Method	Geometrical casting tolerance grade (GCTG) for casting material								
	Steel	Grey iron	S.G. iron	Malleable iron	Copper alloys	Zinc alloys	Light metal alloys	Nickel-based alloys	Cobalt-based alloys
Sand cast, hand moulding	6 to 8	5 to 7	5 to 7	5 to 7	5 to 7	5 to 7	5 to 7	6 to 8	6 to 8
Sand cast, machine moulding and shell moulding	5 to 7	4 to 6	4 to 6	4 to 6	4 to 6	4 to 6	4 to 6	5 to 7	5 to 7
Metallic permanent mould (except pressure die casting)	—	—	—	—	3 to 5	—	3 to 5	—	—
Pressure die casting ^b	—	—	—	—	2 to 4	2 to 4	2 to 4	—	—
Investment casting	a	3 to 5	3 to 5	3 to 5	3 to 5	2 to 4	3 to 5	a	a
<p>a For investment castings, the following apply depending on the largest overall dimension:</p> <ul style="list-style-type: none"> — ≤ 100 mm: grade 4 to 6; — > 100 mm ≤ 400 mm: grade 4 to 8; — > 400 mm: grade 4 to 9. <p>b For investment castings, the following apply:</p> <ul style="list-style-type: none"> — Grade GCTG 2: should only be used by special agreement; — Grade GCTG 3: ordinary castings without side sliders for the contour; — Grade GCTG 4: complex castings as well as castings with side sliders for the contour. 									

Annex B (informative)

Required machining allowance grades (RMAG)

Required machining allowance grades (RMAG) recommended for particular metals and alloys and manufacturing methods are presented in Table B.1.

Table B.1 — Typical required machining allowance grades for raw castings

Method	Required machining allowance grade (RMAG) for casting material								
	Steel	Grey iron	S.G. iron	Malleable iron	Copper alloys	Zinc alloys	Light metal alloys	Nickel-based alloys	Cobalt-based alloys
Sand cast, hand moulding	G to K	F to H ^a	F to H ^a	F to H	F to H	F to H	F to H ^a	G to K	G to K
Sand cast, machine moulding and shell moulding	F to H	E to G	E to G	E to G	E to G	E to G	E to G	F to H	F to H
Metallic permanent mould (except pressure die casting)	—	D to F	D to F	D to F	D to F	D to F	D to F	—	—
Pressure die casting	—	—	—	—	B to D	A to D	B to D	—	—
Investment casting	E	E	E	—	E	—	E	E	E

^a For castings with largest overall dimension greater than 6 300 mm, F to K applies.

Annex C (informative)

Concept of general tolerancing of characteristics

C.1 General tolerances should be indicated on the drawing with reference to this part of ISO 8062, in accordance with Clause 9.

The values of general tolerances correspond to grades of customary foundry accuracy, the appropriate tolerance grade being selected and indicated on the drawing.

C.2 For certain tolerance values, which correspond to the customary foundry accuracy, there is usually no gain in manufacturing economy by enlarging the tolerance. In any event, foundry machinery and usual foundry skills do not normally manufacture features with greater deviations. For example, a feature of 150 mm \pm 1,8 mm diameter by 350 mm long, manufactured in a foundry with a customary accuracy equal to or finer than GCTG 7, contains geometrical deviations well within 4,5 mm for roundness and 3 mm for straightness of surface elements. Specifying larger tolerances would be of no benefit in foundries.

NOTE The values given are taken from Table 5 for roundness and Table 3 for straightness.

However, if, for functional reasons, a feature requires a smaller tolerance value than the “general tolerances”, then the feature should have the smaller tolerance indicated individually adjacent to the particular feature. This type of tolerance falls outside the scope of general tolerances.

In cases where the function of a feature allows a casting tolerance equal to or larger than the general tolerance values, this should not be individually indicated, but should be stated on the drawing as described in Clause 9. This type of tolerance allows full use of the concept of general tolerancing.

Exceptions to the rule exist, where the function allows a larger tolerance than the general tolerances, and the larger tolerance provides a gain in manufacturing economy. In these special cases, the larger casting tolerance should be indicated individually adjacent to the particular feature, e.g. the roundness tolerance of a large and thin ring.

C.3 Using general tolerances gives the following advantages:

- a) drawings are easier to read and thus communication is made more effective to the user of the drawing;
- b) the design draughtsman saves time by avoiding detailed tolerance calculations, as it is sufficient to know that the function allows a tolerance greater than or equal to the general tolerance;
- c) the drawing readily indicates which features can be produced by normal process capability, which in turn assists quality engineering by reducing inspection levels;
- d) those remaining features which have individually indicated casting tolerances are, for the most part, those controlling features for which the function requires relatively small tolerances and which may therefore involve special effort in the production: this is helpful for production planning and assists quality control services in their analysis of inspection requirements;
- e) purchasers can negotiate orders more readily since the “customary foundry accuracy” is known before the contract is placed: this also avoids arguments on delivery between the buyer and the supplier, since in this respect the drawing is complete.

These advantages are fully obtained only if there is sufficient reliability that the general dimensional tolerances, as well as geometrical tolerances and RMA, will not be exceeded, i.e. if the customary foundry accuracy of the particular foundry is equal to or more precise than the general tolerances indicated in the drawing.

The foundry should therefore:

- determine by measurements what its customary foundry accuracy is;
- accept only those drawings which have general tolerances equal to or greater than its customary foundry accuracy;
- determine by sampling that its customary foundry accuracy does not deteriorate.

NOTE It is not the intention of the concept of general tolerancing to check every feature on every casting.

Relying on the notion of undefined “good foundry”, with all its uncertainties and misunderstandings, is no longer necessary with the concept of general tolerances. The general tolerances define the required accuracy of “good foundry”.

C.4 The tolerance that the function allows is often greater than the general tolerance. The function of the parts is, therefore, not always impaired if the general tolerance is (occasionally) exceeded at any feature of the casting. Exceeding the general tolerance should lead to a rejection of the casting only if the function is impaired.

C.5 It is not the intention of the concept of general tolerances, in accordance with this part of ISO 8062, to inspect each general tolerance on each casting, because it is unlikely that the general tolerance will be exceeded.

Annex D (informative)

Datums for general geometrical tolerances

D.1 General

This annex illustrates various cases of datums for the general geometrical tolerances, in accordance with 5.3.3.

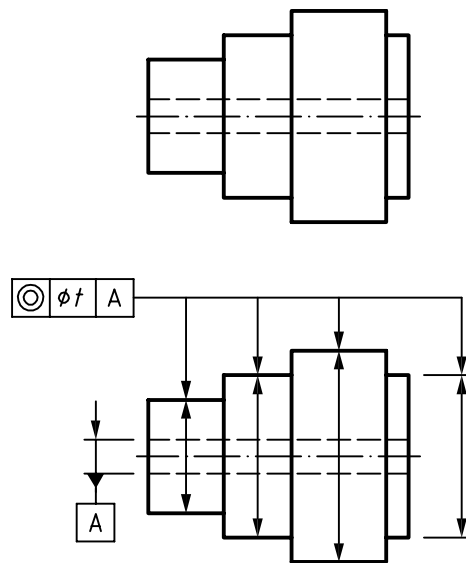

Figure D.1 — Drawing and meaning of general coaxiality tolerances, single datum

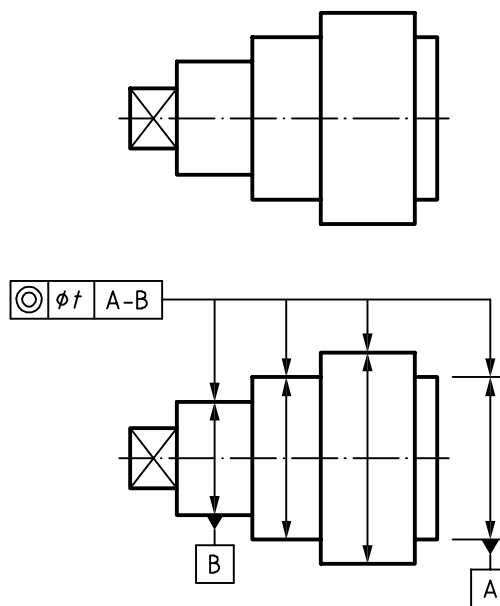

Figure D.2 — Drawing and meaning of general coaxiality tolerances, common datum

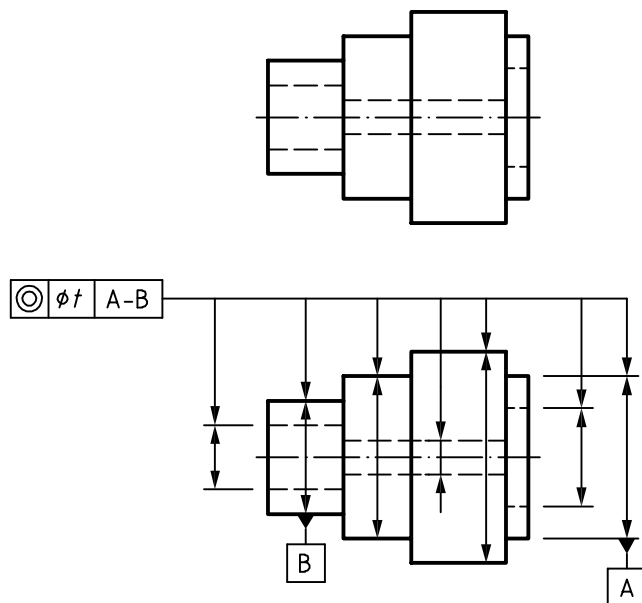

Figure D.3 — Drawing and meaning of general coaxiality tolerances, common datum with the largest diameter (in this case the outer cylinder)

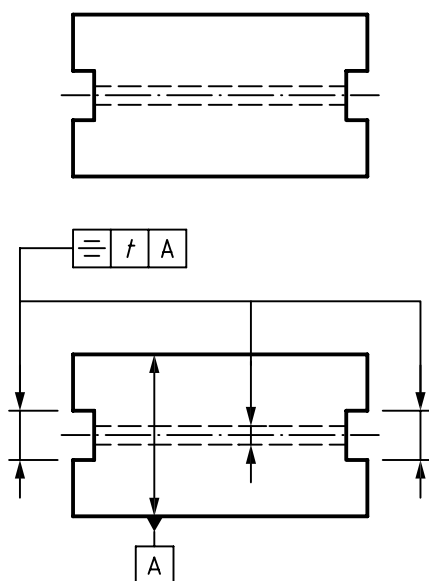

Figure D.4 — Drawing and meaning of general symmetry tolerances, single datum

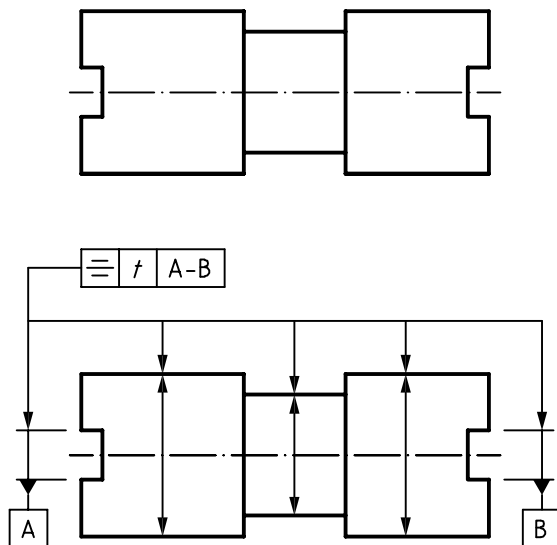

Figure D.5 — Drawing and meaning of general symmetry tolerances, common datum

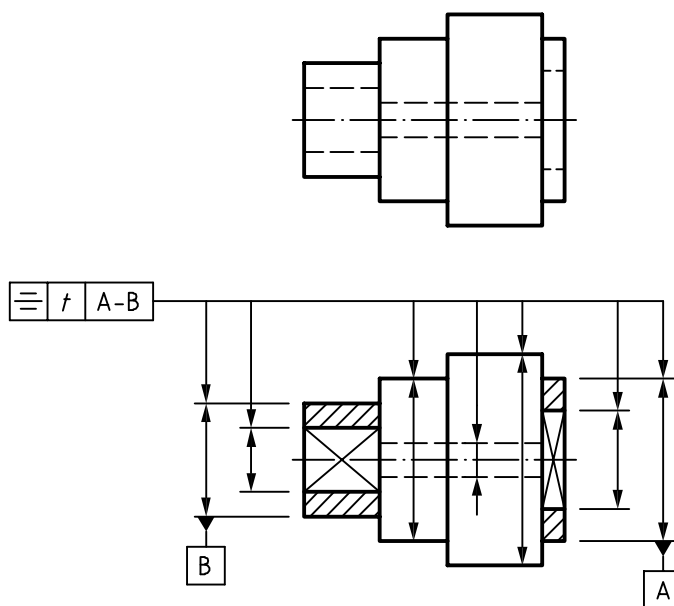

Figure D.6 — Drawing and meaning of general symmetry tolerances, common datum with largest sizes

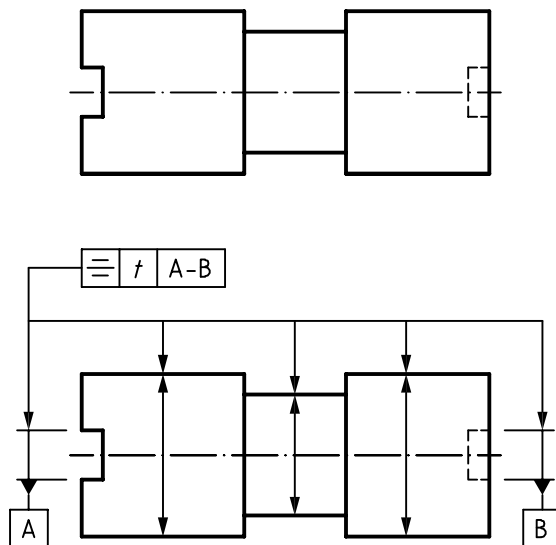

Figure D.7 — Drawing and meaning of general symmetry tolerances, common datum, one datum cylindrical

E.2 Form tolerance

E.2.1 Straightness tolerance

General straightness tolerances are applied to eight features in Figure E.2. The tolerance values are selected from Table 3.

Dimensions in millimetres

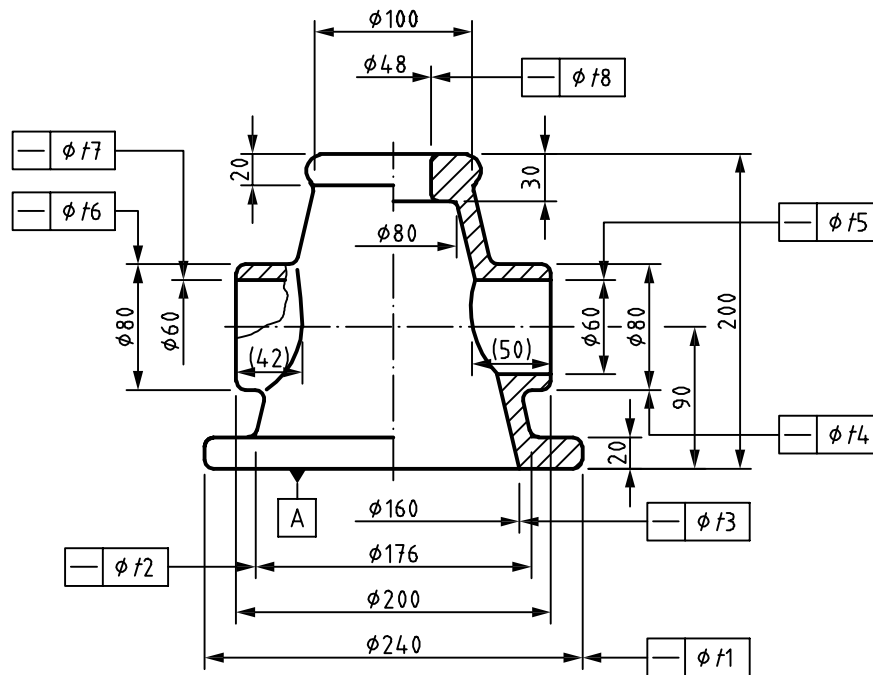

Figure E.2 — General straightness tolerances

The eight features are as follows:

- a) axis of external cylinder of bottom flange (nominal dimension is 20 mm): t_1 is 0,6 mm;
- b) axis of external cone [nominal dimension is 150 mm, i.e. 200 mm – 20 mm (bottom) – 30 mm (top)]: t_2 is 1,4 mm;
- c) axis of internal cone [nominal dimension is 170 mm, i.e. 200 mm – 30 mm (top)]: t_3 is 1,4 mm;
- d) axes of horizontal and external cylinders (nominal dimension is 42 mm): t_4 and t_6 are 0,9 mm;

NOTE If a common tolerance zone is required to the axes of the horizontal and external cylinders, a straightness tolerance is indicated individually by symbol CZ, in accordance with ISO 1101.

- e) axes of horizontal holes (nominal dimension is 50 mm): t_5 and t_7 are 0,9 mm;

NOTE If a common tolerance zone is required to the axes of the horizontal holes, a straightness tolerance is indicated by symbol CZ, in accordance with ISO 1101.

- f) axis of hole of top part (nominal dimension is 30 mm): t_8 is 0,6 mm.

E.2.2 Flatness tolerance

General flatness tolerances are applied to six features in Figure E.3. The tolerance values are selected from Table 4.

Dimensions in millimetres

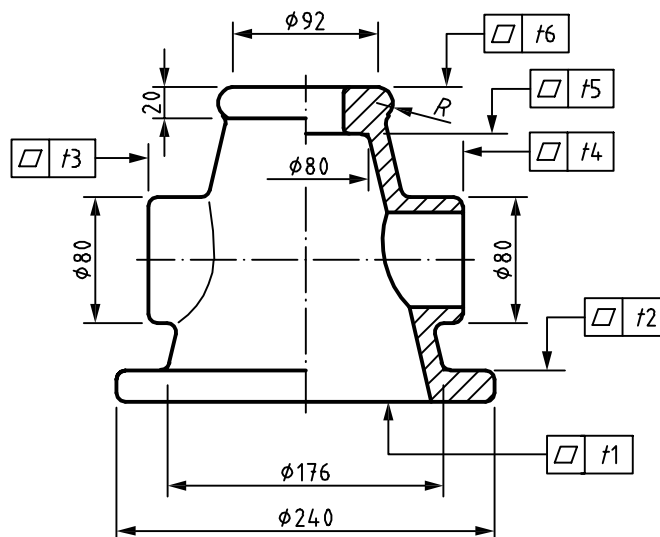

Figure E.3 — General flatness tolerances

The six features are as follows:

- lower flat surface of bottom flange (nominal dimension is \varnothing 240 mm): t_1 is 2 mm;
- upper flat surface of bottom flange (nominal dimension is \varnothing 240 mm): t_2 is 2 mm;
- right and left side feature of horizontal cylinder (nominal dimension is \varnothing 80 mm): t_3 and t_4 are 1,4 mm;
- flat feature of smaller end of internal cone (nominal dimension is \varnothing 80 mm): t_5 is 1,4 mm;
- upper flat feature [nominal dimension is \varnothing 92 mm, i.e. $112 \text{ mm} - (10 \times 2 \text{ mm})$]: t_6 is 1,4 mm.

E.2.3 Roundness tolerance

General roundness tolerances are applied to nine features in Figure E.4. The tolerance values are selected from Table 5.

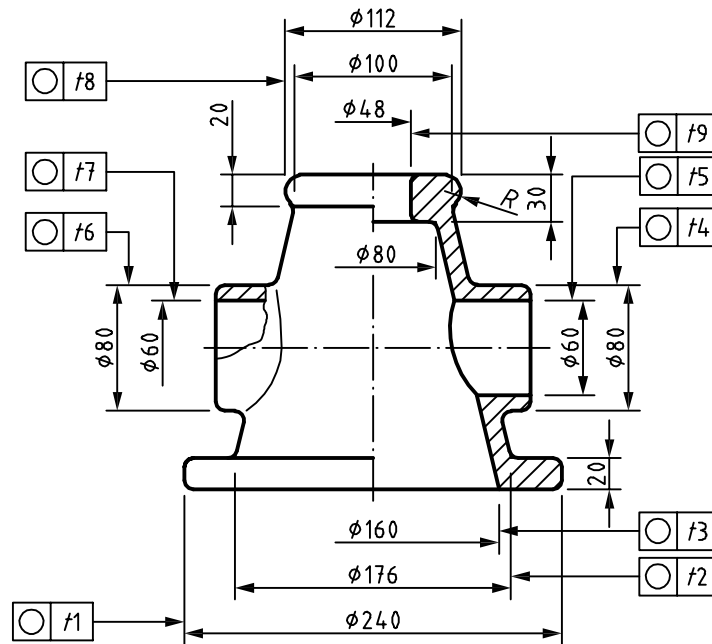

Figure E.4 — General roundness tolerances

The nine features are as follows:

- a) external cylindrical feature of bottom flange (nominal dimension is \varnothing 240 mm): t_1 is 3 mm;
- b) external feature of cone (nominal maximum dimension is \varnothing 176 mm): t_2 is 3 mm;
- c) internal feature of cone (nominal maximum dimension is \varnothing 160 mm): t_3 is 3 mm;
- d) external features of horizontal cylinder (nominal dimension is \varnothing 80 mm): t_4 and t_6 are 2 mm;
- e) internal features of horizontal hole (nominal dimension is \varnothing 60 mm): t_5 and t_7 are 2 mm;
- f) external feature of top part (nominal dimension is \varnothing 112 mm): t_8 is 3 mm;
- g) internal feature of top hole (nominal dimension is \varnothing 48 mm): t_9 is 2 mm.

E.2.4 Cylindricity tolerance

General cylindricity tolerances are applied by considering the following three components of opposite generating lines of a cylindrical feature:

- general straightness tolerance,
- roundness tolerance, and
- parallelism tolerance.

Each of those components is limited by its general tolerances.

E.3 Orientation tolerance

E.3.1 Parallelism tolerance

General parallelism tolerances are applied to eight features from datum in Figure E.5. The tolerance values are selected from Table 5.

Dimensions in millimetres

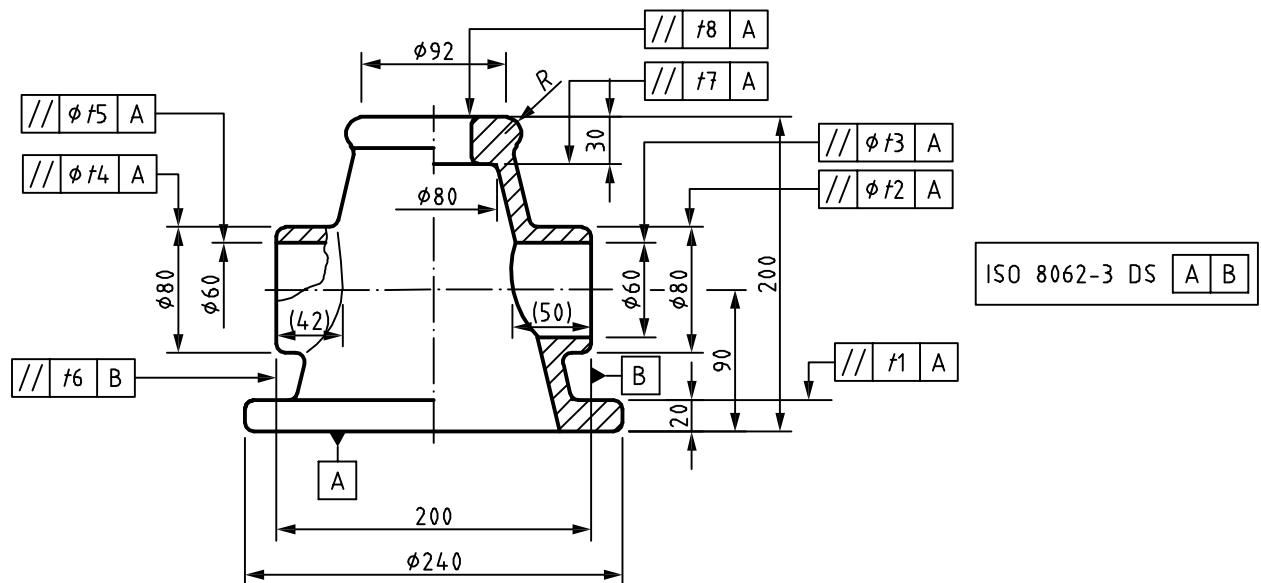

Figure E.5 — General parallelism tolerances

The eight features are as follows:

- upper feature of bottom flange (nominal dimension is $\phi 240$ mm) and parallel to datum A: t_1 is 3 mm;
- right and left hand axes of horizontal and external cylinder (nominal dimension is 42 mm) and parallel to datum A: t_2 and t_4 are 2 mm;

NOTE If a common tolerance zone is required to the axes of horizontal and external cylinders, a parallelism tolerance is indicated by symbol CZ, in accordance with ISO 1101.

- right and left hand axes of horizontal holes (nominal dimension is 50 mm) and parallel to datum A: t_3 and t_5 are 2 mm;

NOTE If a common tolerance zone is required to the axes of the horizontal and external cylinders, a parallelism tolerance is indicated by symbol CZ, in accordance with ISO 1101.

- left hand end surface of horizontal cylinder (nominal dimension is $\phi 80$ mm) and parallel to datum B: t_6 is 2 mm.
- flat feature of smaller side of cone (nominal dimension is $\phi 80$ mm) and parallel to datum A: t_7 is 2 mm;
- flat feature of upper part [nominal dimension is $\phi 92$ mm, i.e. 112 mm – (10×2) mm] and parallel to datum A: t_8 is 2 mm.

E.3.2 Perpendicularity tolerance

General perpendicularity tolerances are applied to six features from datum in Figure E.6. The tolerance values are selected from Table 5.

Dimensions in millimetres

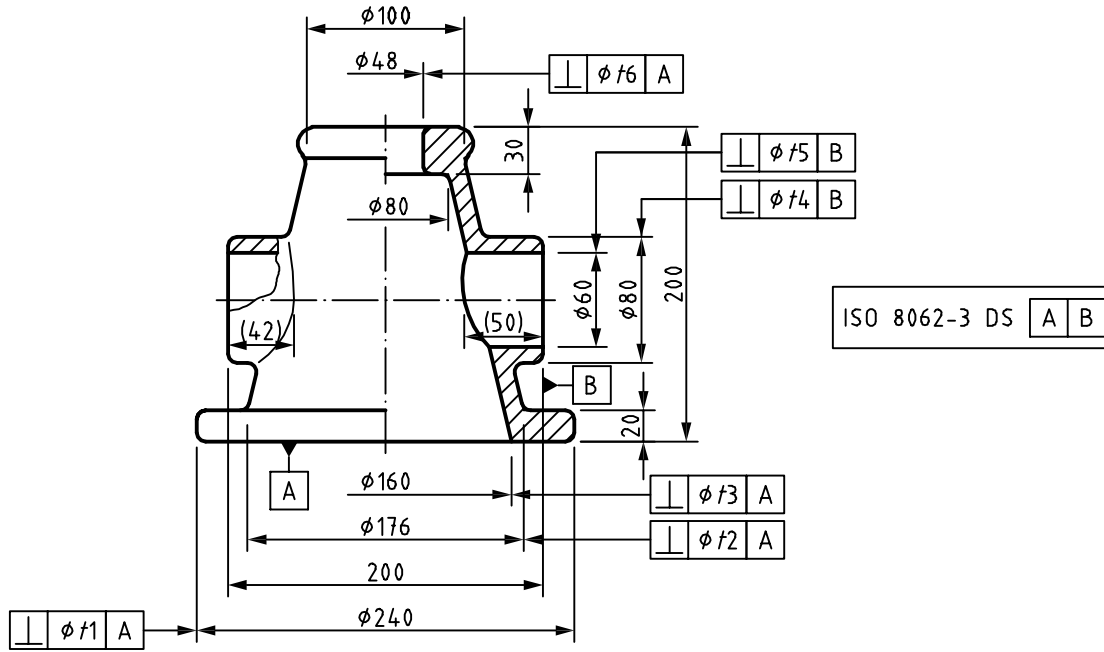

Figure E.6 — General perpendicularity tolerances

The six features are as follows:

- a) axis of bottom flange (nominal dimension is 20 mm) and perpendicular to datum A: $t1$ is 1,4 mm;
 - b) axis of external cone (nominal dimension is 150 mm) and perpendicular to datum A: $t2$ is 3 mm;
 - c) axis of internal cone (nominal dimension is 170 mm) and perpendicular to datum A: $t3$ is 3 mm;
 - d) axis of right hand horizontal and external cylinder (nominal dimension is 42 mm) and perpendicular to datum B: $t4$ is 2 mm;
- NOTE $t4$ is also applied to axis of left hand horizontal and external cylinder.
- e) axis of right hand of horizontal hole (nominal dimension is 50 mm) and perpendicular to datum B: $t5$ is 2 mm;
- NOTE $t5$ is also applied to axis of left hand horizontal hole.
- f) axis of hole of top part (nominal dimension is 30 mm) and perpendicular to datum A: $t6$ is 1,4 mm.

E.4 Location tolerance

E.4.1 Coaxiality tolerance

General coaxiality tolerances are applied to nine features in Figure E.7. The tolerance values are selected from Table 6. In accordance with 5.3.3.2, the datums selected are those illustrated in Figure E.7.

Dimensions in millimetres

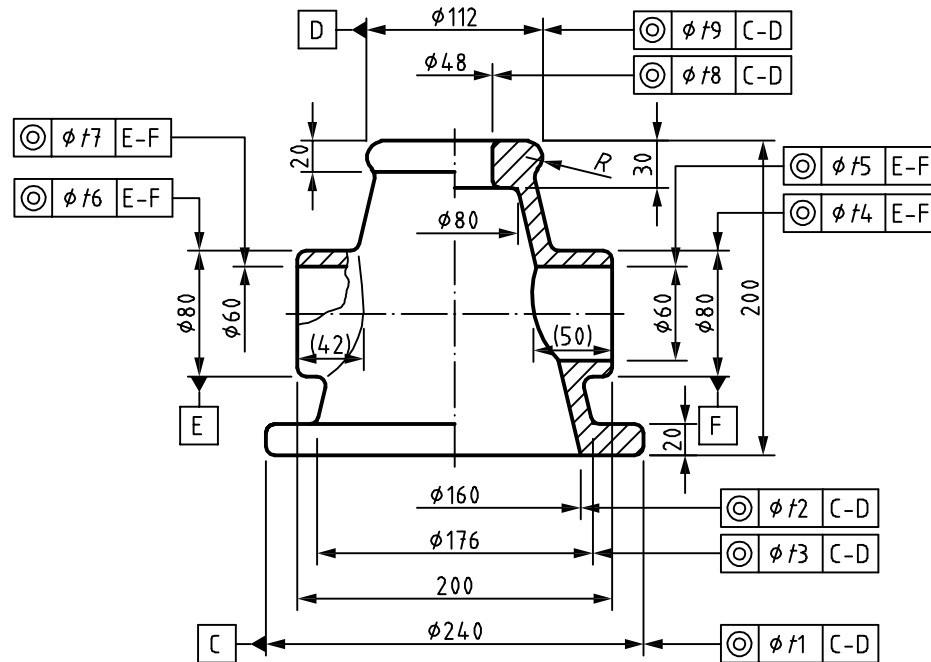

Figure E.7 — General coaxiality tolerances

The nine features are as follows:

- axis of external cylinder of bottom flange (nominal dimension is 20 mm) and coaxial to common datum C-D: t_1 is 2 mm;
- axis of internal cone (nominal larger dimension is 160 mm) and coaxial to common datum C-D: t_2 is 4,5 mm;
- axis of external cone (nominal larger dimension is 176 mm) and coaxial to common datum C-D: t_3 is 4,5 mm;
- axis of right hand horizontal and external cylinder (nominal dimension is 42 mm) and coaxial to common datum E-F: t_4 is 3 mm;
- axis of right hand horizontal and internal cylinder (nominal dimension is 50 mm) and coaxial to common datum E-F: t_5 is 3 mm;
- axis of left hand horizontal and external cylinder (nominal dimension is 42 mm) and coaxial to common datum E-F: t_6 is 3 mm;
- axis of left hand horizontal and internal cylinder (nominal dimension is 50 mm) and coaxial to common datum E-F: t_7 is 3 mm;

- h) axis of hole of top part (nominal dimension is 30 mm) and coaxial to common datum C-D: ± 0.02 mm;
- i) axis of external cylinder of top part (nominal dimension is 20 mm) and coaxial to common datum C-D: ± 0.02 mm.

E.4.2 Symmetry tolerance

A general symmetry tolerance is applied to one feature and symmetry to common datum C-D, ± 0.02 mm in Figure E.8. The tolerance value is selected from Table 5.

Dimensions in millimetres

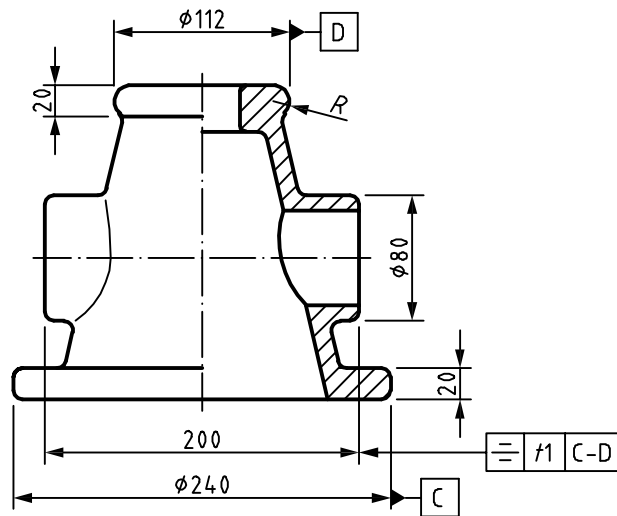

Figure E.8 — General symmetry tolerance

The general symmetry tolerances are applied to the median plane of the two end surfaces of the horizontal cylinder (nominal dimension is $\varnothing 80$ mm) and the symmetry to common datum C-D: ± 0.02 mm.

Annex F (informative)

Relation to the GPS matrix model

For full details about the GPS matrix model, see ISO/TR 14638.

F.1 Information about the standard and its use

This part of ISO 8062 specifies a system of general dimensional and geometrical tolerances, as well as machining allowance grades, for castings as delivered to the purchaser. It is applicable for the tolerancing of dimensions and geometry of castings in all cast metals and their alloys produced by various casting manufacturing processes.

F.2 Position in the GPS matrix model

This part of ISO 8062 is a geometrical product specification (GPS) standard and is to be regarded as a complementary process specific tolerance GPS standard (see ISO/TR 14638). It influences link 2 of the chain of standards on mouldings, as graphically illustrated in Figure F.1.

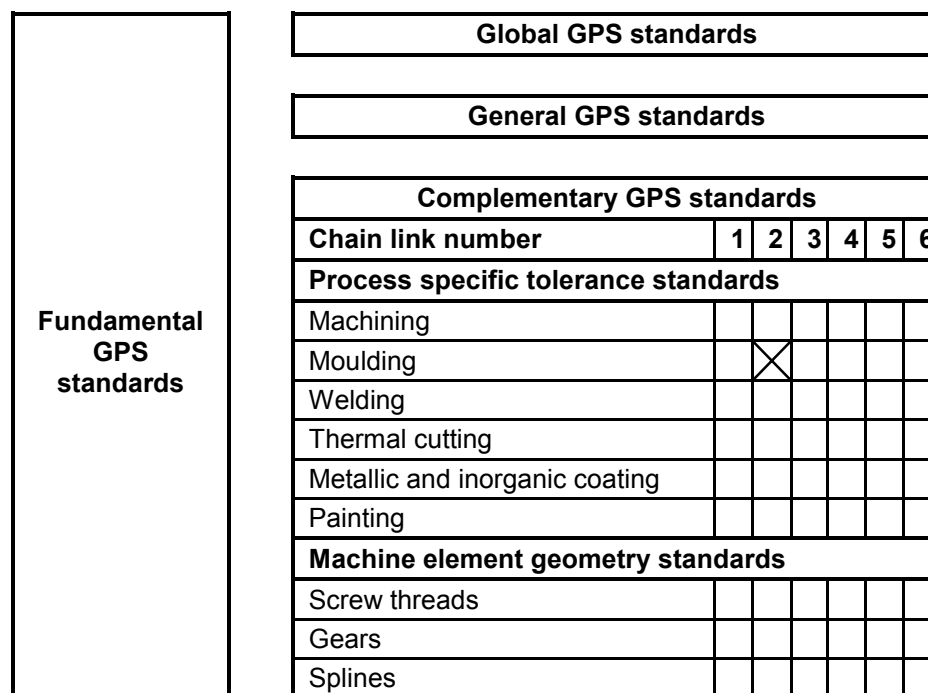

Figure F.1 — Position in the GPS matrix model

F.3 Related standards

The related International Standards are those of the chains of standards indicated in Figure F.1.

Bibliography

- [1] ISO 8015:1985, *Technical drawings — Fundamental tolerancing principle*
- [2] ISO/TR 14638:1995, *Geometrical product specification (GPS) — Masterplan*

.....

ICS 17.040.10

Price based on 30 pages